

---

# Plain bearings — Wrapped bushes —

**Part 7: Measurement of wall thickness  
of thin-walled bushes**

DRAFT

---

---

**Plain bearings — Wrapped bushes —**  
**Part 7:**  
**Measurement of wall thickness**  
**of thin-walled bushes**

*Paliers lisses — Bagues roulées —*

*Partie 7: Mesurage de l'épaisseur de paroi des bagues minces*

**Contents**

Page

Foreword..... iv

1 Scope ..... 1

2 Normative references ..... 1

3 Terms and definitions..... 1

4 Symbols and units ..... 2

5 Purpose of checking..... 2

6 Checking methods..... 2

7 Requirements for measuring equipment for the contact method ..... 5

8 Checking of measuring equipment..... 5

Bibliography ..... 6

DRAFT

## Foreword

ISO (the International Organization for Standardization) is a worldwide federation of national standards bodies (ISO member bodies). The work of preparing International Standards is normally carried out through ISO technical committees. Each member body interested in a subject for which a technical committee has been established has the right to be represented on that committee. International organizations, governmental and non-governmental, in liaison with ISO, also take part in the work. ISO collaborates closely with the International Electrotechnical Commission (IEC) on all matters of electrotechnical standardization.

International Standards are drafted in accordance with the rules given in the ISO/IEC Directives, Part 2.

Draft International Standards adopted by the technical committees are circulated to the member bodies for voting. Publication as an International Standard requires approval by at least 75 % of the member bodies casting a vote.

Attention is drawn to the possibility that some of the elements of this International Standard may be the subject of patent rights. ISO shall not be held responsible for identifying any or all such patent rights.

International Standard ISO 3547-7 was prepared by Technical Committee ISO/TC 123, *Plain bearings*, Subcommittee SC 5, *Quality analysis and assurance*.

This part of ISO 3547 cancels and replaces ISO 12306:1994, which has been technically revised.

ISO 3547 consists of the following parts, under the general title *Plain bearings — Wrapped bushes*:

- *Part 1: Dimensions*
- *Part 2: Test data for outside and inside diameters*
- *Part 3: Lubrication holes, grooves and indentations*
- *Part 4: Materials*
- *Part 5: Checking the outside diameter*
- *Part 6: Checking the inside diameter*
- *Part 7: Measurement of wall thickness of thin-walled bushes*

# Plain bearings — Wrapped bushes —

## Part 7: Measurement of wall thickness of thin-walled bushes

### 1 Scope

This part of ISO 3547 describes, following ISO 12301, the checking methods and measuring equipment used for measuring the total wall thickness of thin-walled bushes in the finished state.

NOTE All dimensions in this International Standard are given in millimetres.

### 2 Normative references

The following referenced documents are indispensable for the application of this document. For dated references, only the edition cited applies. For undated references, the latest edition of the referenced document (including any amendments) applies.

ISO 3547-1, *Plain bearings — Wrapped bushes — Part 1: Dimensions*

ISO 4379, *Plain bearings — Copper alloy bushes*

### 3 Terms and definitions

For the purposes of this document, the following terms and definitions apply.

#### 3.1 wall thickness

$s_3$   
radial distance between the opposing measuring points at the inside and the outside surface diameter

See Figure 1.

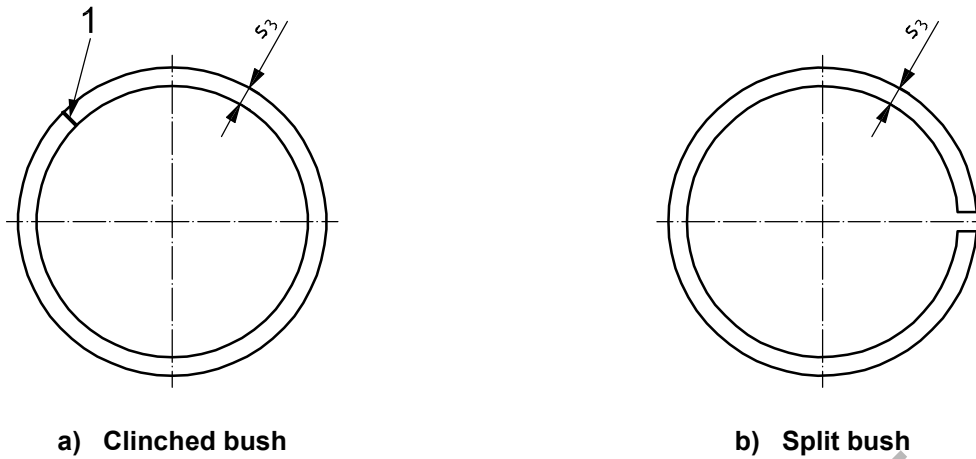

#### Key

1 clinch

Figure 1 — Wall thickness,  $s_3$

## 4 Symbols and units

For the purposes of this document, the symbols and units given in Table 1 apply.

Table 1 — Symbols and units

Symbol	Parameter	SI unit
$a_{ch}$	Distance to measuring position	millimetre
$B$	Width of the bush	millimetre
$D_o$	Outside diameter of the bush	millimetre
$F_{pin}$	Measuring pin load	newton
$s_3$	Wall thickness	millimetre

## 5 Purpose of checking

The purpose of checking is to ensure that the wall thickness and wall thickness tolerances are in accordance with ISO 3547-1 and ISO 4379. If this measurement is required, it is designated  $S$ ; see ISO 3547-1.

## 6 Checking methods

### 6.1 Measuring principle

The gauging axis of the measuring device shall be in the radial direction and at a right angle to the outside surface of the test piece in order to find the minimum value of the wall thickness. The measured values may be recorded by a single measurement or by a sum measurement, as represented symbolically in Figure 2.

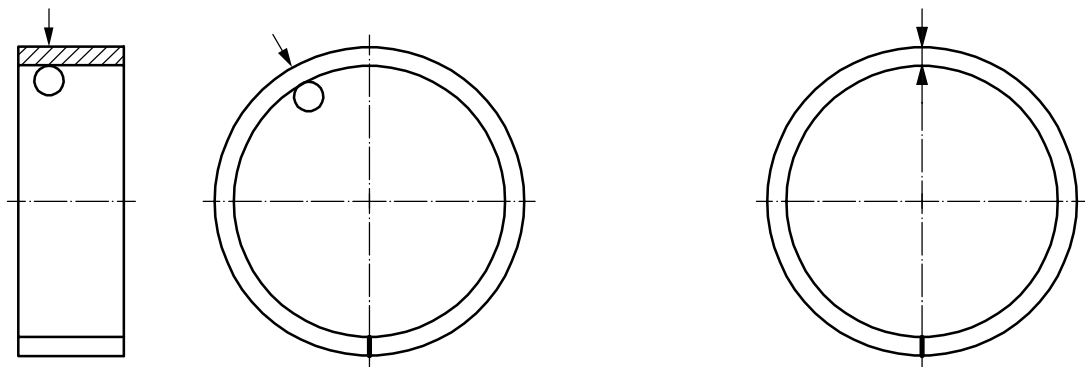

a) Single measurement by contact  
(mechanical/electronic gauge)

b) Sum measurement by contact/non-contact  
(electronic/pneumatic gauge)

Figure 2 — Measuring principle of wall thickness measurement

The presence of lubricating holes, oil pockets, oil grooves, markings or special chamfers can require deviation from the measuring lines and measuring points specified in 6.2 and 6.3. Any such deviation shall be agreed upon separately.

Any wall thickness not conforming to the specified values due to the manufacturing process, because of deformation of the bearing backing in the area of marking or at non-load-bearing places of wrapped bushes, shall be defined separately.

## 6.2 Line measurement around the circumference

Continuous measurement of the wall thickness around the circumference shall be carried out at the measuring lines specified in Figure 3 and Table 2.

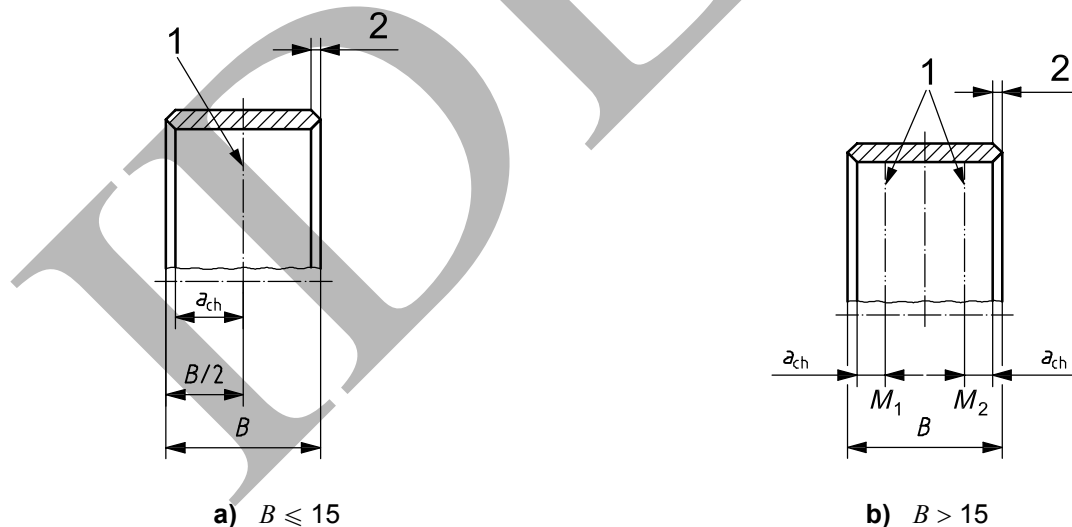

a)  $B \leq 15$

b)  $B > 15$

### Key

- 1 measuring lines,  $M$
- 2 chamfer

Figure 3 — Position of measuring lines

**Table 2 — Distance to measuring position,  $a_{ch}$**

Dimensions in millimetres

$B$		Distance to measuring position <sup>a</sup> $a_{ch}$	Number of measuring lines, $M$
—	$\leq 15$	$B/2$	1
$> 15$	$\leq 50$	4	2
$> 50$	—	6	2

<sup>a</sup> Each measuring line distance,  $a_{ch}$ , is specified from the beginning of the sliding surface or from the end face by adding the nominal value of the chamfer.

### 6.3 Point measurement

Point-by-point measurement of wall thickness shall be carried out at the measuring points specified in Figure 4 for widths of  $B \leq 90$  mm and outside diameter  $D_o \leq 150$  mm. In the case where  $B > 90$  mm and  $D_o > 150$  mm, the measurement method shall be subject to agreement between the supplier and user. The measuring position distance,  $a_{ch}$ , shall be taken from Table 2.

Dimensions in millimetres

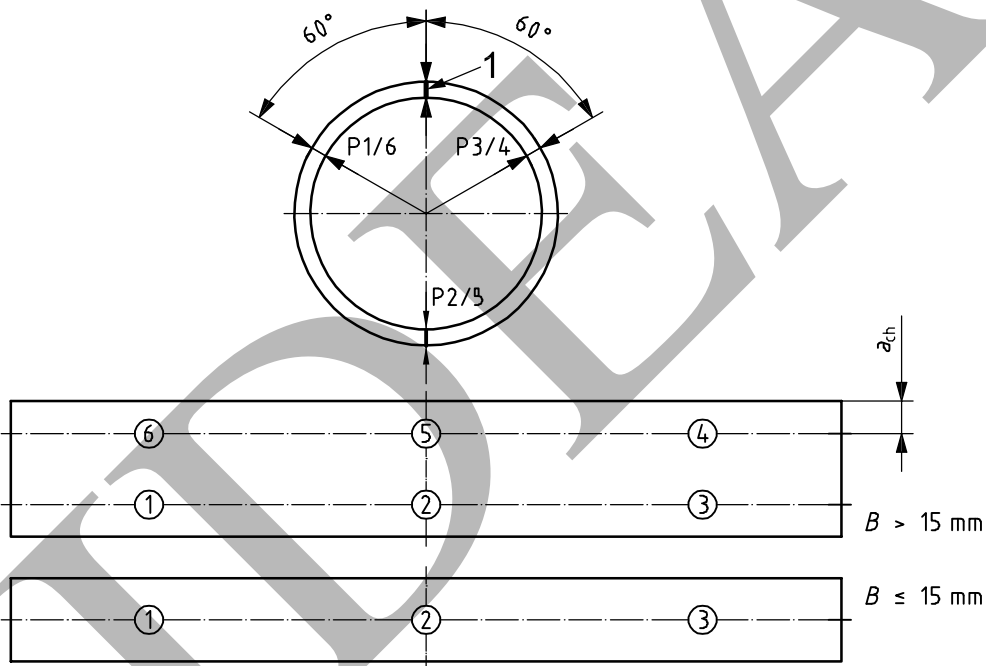

**Key**

- 1 split position
- P measuring points

**Figure 4 — Three- or six-point measuring scheme**

## 7 Requirements for measuring equipment for the contact method

### 7.1 Radius of the measuring pin on the outside surface

The radius of the measuring pin positioned on the outside shall be  $1,5 \text{ mm} \pm 0,2 \text{ mm}$  as shown in Figure 5.

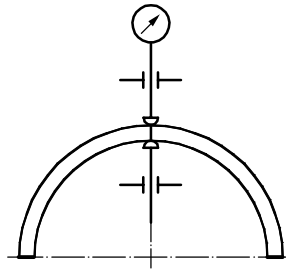

Figure 5 — Measuring equipment for the contact method

### 7.2 Radius of the measuring pin on the inside surface

The radius of the measuring pin positioned on the inside is given in Table 3 as a function of the bush outside diameter  $D_o$  and the bearing material.

Table 3 — Radius of the measuring pin on the inside surface

Dimensions in millimetres

$D_o$ nominal		Radius of the measuring pin	
		Metallic bushes	Polymer bushes
—	$\leq 10$	$1,5 \pm 0,2$	$1,5 \pm 0,2$
$> 10$	$\leq 25$	$3 \pm 0,2$	$3 \pm 0,2$
$> 25$	$\leq 150$	$3 \pm 0,2$	$5 \pm 0,2$
$> 150$	—	$5 \pm 0,2$	$5 \pm 0,2$

### 7.3 Measuring pin load

The measuring pin load,  $F_{pin}$ , applied onto the sliding layer, shall be 0,8 N to 2,5 N in accordance with ISO 12301.

## 8 Checking of measuring equipment

The measuring equipment shall be checked for uncertainty of measurement at a frequency specified by the user, based on the type of equipment and on experience from previous checks. The limits shall comply with the current industry requirements.

## Bibliography

- [1] ISO 3547-2, *Plain bearings — Wrapped bushes — Part 2: Test data for outside and inside diameters*
- [2] ISO 12301, *Plain bearings — Quality control techniques and inspection of geometrical and material quality characteristics*

IDEAL