Plain bearings — Wrapped bushes —

**Part 2: Test data for outside and inside
diameters**

IDEAL

Plain bearings — Wrapped bushes —

Part 2:

**Test data for outside and inside
diameters**

Paliers lisses — Bagues roulées —

*Partie 2: Données d'essai pour le diamètre extérieur et le diamètre
intérieur*

Contents

Page

Foreword..... iv

1 Scope 1

2 Normative references 1

3 Terms and definitions 1

4 Symbols and units 2

5 Presentation of data on drawing 2

6 Tests 4

6.1 Test A 4

6.2 Test B 4

6.3 Test C 4

6.4 Test D 4

7 Test A 4

7.1 Description 4

7.2 Calculation basis 4

7.3 Obtaining data — Example 7

7.4 Presentation of data on drawing — Example 8

8 Test B 8

8.1 Description 8

8.2 Obtaining data — Example 9

8.3 Presentation of data on drawing — Example 9

9 Test C 9

9.1 Description 9

9.2 Obtaining data — Example 10

9.3 Presentation of data on drawing — Example 11

10 Test D 11

10.1 Description 11

10.2 Obtaining data — Example 11

10.3 Presentation of data on drawing — Example 12

11 Designation of tests according to this part of ISO 3547 12

Foreword

ISO (the International Organization for Standardization) is a worldwide federation of national standards bodies (ISO member bodies). The work of preparing International Standards is normally carried out through ISO technical committees. Each member body interested in a subject for which a technical committee has been established has the right to be represented on that committee. International organizations, governmental and non-governmental, in liaison with ISO, also take part in the work. ISO collaborates closely with the International Electrotechnical Commission (IEC) on all matters of electrotechnical standardization.

International Standards are drafted in accordance with the rules given in the ISO/IEC Directives, Part 2.

The main task of technical committees is to prepare International Standards. Draft International Standards adopted by the technical committees are circulated to the member bodies for voting. Publication as an International Standard requires approval by at least 75 % of the member bodies casting a vote.

Attention is drawn to the possibility that some of the elements of this document may be the subject of patent rights. ISO shall not be held responsible for identifying any or all such patent rights.

ISO 3547-2 was prepared by Technical Committee ISO/TC 123, *Plain bearings*, Subcommittee SC 3, *Dimensions, tolerances and construction details*.

This second edition cancels and replaces the first edition (ISO 3547-2:1999), which has been technically revised.

ISO 3547 consists of the following parts, under the general title *Plain bearings — Wrapped bushes*:

- *Part 1: Dimensions*
- *Part 2: Test data for outside and inside diameters*
- *Part 3: Lubrication holes, grooves and indentations*
- *Part 4: Materials*

The following parts are under preparation:

- *Part 5: Checking the outside diameter*
- *Part 6: Checking the inside diameter*
- *Part 7: Measurement of wall thickness of thin-walled half-bearings and thin-walled bushes*

Plain bearings — Wrapped bushes —

Part 2: Test data for outside and inside diameters

1 Scope

This part of ISO 3547 specifies the test data for outside and inside diameters of wrapped bushes made of solid and multi-layer bearing material for plain bearing applications. It also specifies test designations.

Since the wall thickness of the bush is measured in the free condition, no special test data is required for this on the drawing (see ISO 3547-5 and ISO 3547-6).

NOTE Depending on the manufacturing method, the back of the bushes can show isolated light depressions and, similarly, bushes with lubrication holes, grooves and bore indentations can show distortion. The wall thickness must therefore be measured away from these areas.

2 Normative references

The following referenced documents are indispensable for the application of this document. For dated references, only the edition cited applies. For undated references, the latest edition of the referenced document (including any amendments) applies.

ISO 3547-1:2006, *Plain bearings — Wrapped bushes — Part 1: Dimensions*

ISO 3547-4:2006, *Plain bearings — Wrapped bushes — Part 4: Materials*

ISO 4378-1, *Plain bearings — Terms, definitions and classification — Part 1: Design, bearing materials and their properties*

ISO 12301, *Plain bearings — Quality control techniques and inspection of geometrical and material quality characteristics*

ISO 13715, *Technical drawings — Edges of undefined shape — Vocabulary and indication*

3 Terms and definitions

For the purposes of this document, the terms and definitions given in ISO 4378-1 apply.

4 Symbols and units

See Table 1.

Table 1 — Symbols and units

Symbol	Description	Unit
A_{cal}	Reduced area of cross section (calculated value) of the bush	mm ²
B	Width of the bush	mm
C_i	Inside chamfer	mm
C_o	Outside chamfer	mm
D_{fl}	Flange diameter	mm
D_H	Housing bore diameter	mm
D_i	Inside diameter of the bush	mm
$D_{i, ch}$	Inside diameter of the bush in the ring gauge	mm
D_o	Outside diameter of the bush	mm
F_{ch}	Checking load	mm
$d_{ch, 1}$	Diameter of the checking block or ring gauge	mm
$d_{ch, 2}$	Diameter of the setting plug or plug gauge	mm
r	Flange radius	mm
s_1	Thickness of the backing layer ^a	mm
s_2	Thickness of the bearing material layer ^a	mm
s_3	Wall thickness ^a	mm
s_{fl}	Flange thickness	mm
ΔD_o	Tolerance of D_o	mm
v	Elastic reduction of the outside diameter under checking load F_{ch}	mm
z	Distance apart of the halves of the checking block	mm
Δz	Indicator reading	mm
Δz_D	Circumference indicator reading for test D	mm

^a For bushes which are made of a single material, $s_1 = s_3$ or $s_2 = s_3$.

5 Presentation of data on drawing

The drawing should show either

- the outside diameter, D_o , and the wall thickness, s_3 , or
- the outside diameter, D_o , and the inside diameter, D_i .

Wall thickness, s_3 , and inside diameter, D_i , shall not be specified together on the same drawing.

See Figure 1.

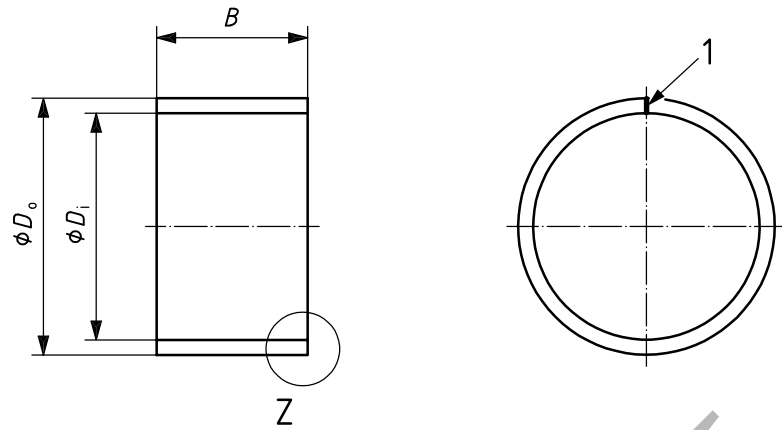

Type C cylindrical bush

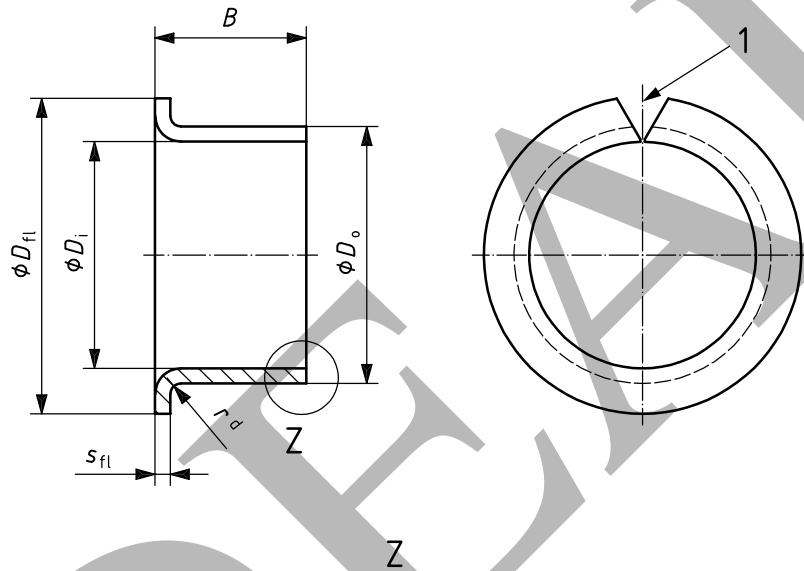

Type F flanged bush

Key

- 1 split
- a Thickness of the bearing material layer: only valid as a basis for calculation in accordance with 7.2.
- b C_i may be a chamfer or break edge, in accordance with ISO 13715.
- c 0,2 mm min. for nominal wall thickness 0,5 mm.
- d $r_{max} = s_3$.

Figure 1 — Cylindrical and flanged bush

6 Tests

6.1 Test A

Check the outside diameter, D_o , using a checking block in a test rig and setting plug, in accordance with Clause 7.

6.2 Test B

Check the outside diameter, D_o , using two ring gauges, in accordance with Clause 8.

6.3 Test C

Check the inside diameter, D_i , of a bush pressed into a ring gauge, in accordance with Clause 9.

6.4 Test D

Check the outside diameter, D_o , using precision measuring tape, in accordance with Clause 10.

7 Test A

7.1 Description

This test is applicable to $2D_o$ up to 180 mm.

The test rig consists of a base on which the two parts of the checking block are mounted (see ISO 3547-5).

A setting plug is inserted in the checking block and the two halves of the checking block are pressed towards one another using the given checking load, F_{ch} , and the indicator reading set.

The setting plug is then removed and replaced by the bush to be checked, and the checking load reapplied.

After the bush has been inserted, the distance, z , between the two halves of the checking block changes under checking load F_{ch} and the distance indicator reading, Δz , is recorded.

From this, D_o can be calculated.

Flanged bushes may be checked either before or after flange forming at the option of the manufacturer.

7.2 Calculation basis

7.2.1 Elastic reduction, v , of outside diameter, D_o

The elastic reduction, v , of the outside diameter, D_o , is the difference between D_o under zero load and the resultant diameter when the checking load, F_{ch} , is applied. Force F_{ch} shall be sufficient to ensure that the bush conforms properly to the surface of the test housing and that the results in the elastic reduction, v , of the outside diameter are in accordance with Table 2.

Table 2 — Elastic reduction, v , of the outside diameter, D_o , under checking load, F_{ch}

Dimensions in millimetres

D_o nominal		v
	≤ 6	0,003
> 6	≤ 12	0,006
> 12	≤ 80	0,013
> 80	≤ 180	0,025

7.2.2 Calculation of diameter of checking block, $d_{ch,1}$

The diameter of the checking block can be calculated from the specified upper limit of the outside diameter, $D_{o,max}$, of the bush from the equation:

$$d_{ch,1} = D_{o,max} - v$$

7.2.3 Effective cross-sectional area, A_{cal}

In order to calculate the checking load, F_{ch} , the effective cross-sectional area, A_{cal} , of the bush shall first be determined.

A_{cal} depends on the material type, bush width B , s_1 and s_2 . See Table 3.

Table 3 — Nominal dimensions for wall thickness, s_3 , backing material, s_1 , and bearing layer, s_2

Dimensions in millimetres

Wall thickness (see ISO 3547-1)	Nominal thicknesses	
	Backing material of bushes made from multi-layer materials	Bearing material layer of bushes made from multi-layer materials
s_3	s_1	s_2
0,5	0,3	0,2
0,75	0,53	0,22
1,0	0,68	0,32
1,5	1,1	0,4
2,0	1,55	0,45
2,5	2,05	0,45

The nominal size for B , s_1 and s_2 shall then be substituted into the corresponding equation given in Table 4.

Table 4 — Calculation of effective cross-sectional area, A_{cal}

Material designation key (according to ISO 3547-4)	Calculation of effective cross sectional area A_{cal}
D1, D2, P1, P2, T1, T2, Z1	$A_{cal} = B \times s_1$
B1, B2, D3, W1, W2, Y1, Y2	$A_{cal} = B \times \frac{s_1}{2}$
D4	$A_{cal} = B \times \frac{s_1}{3}$
R1, R2, R3, R4	$A_{cal} = B \times \left(s_1 + \frac{s_2}{3} \right)$
S1, S2, S3, S4, S5, S6	$A_{cal} = B \times \left(s_1 + \frac{s_2}{2} \right)$

7.2.4 Calculation of checking load, F_{ch}

See Table 5.

Table 5 — Formulae for F_{ch}

Dimensions in millimetres

D_o nominal		F_{ch}
	≤ 6	$1\,500 \times \frac{A_{cal}}{d_{ch,1}}$ (rounded up 100 N)
> 6	≤ 12	$3\,000 \times \frac{A_{cal}}{d_{ch,1}}$ (rounded up 250 N)
> 12	≤ 80	$6\,000 \times \frac{A_{cal}}{d_{ch,1}}$ (rounded up 500 N)
> 80	≤ 180	$12\,000 \times \frac{A_{cal}}{d_{ch,1}}$ (rounded up 500 N)
NOTE When calculating F_{ch} , the factor 1 500, 3 000, 6 000 or 12 000 has the unit N/mm.		

Lubrication grooves can reduce A_{cal} , depending upon their shape, position and method of manufacture. If the proportion is over 10 %, this shall be considered in the calculation.

For bushes which are not made in accordance with ISO 3547-1, the arithmetic average of the two limiting dimensions rounded up to the nearest 0,1 mm shall be used for B , s_1 and s_2 .

7.2.5 Limits for Δz

Upper limit: 0

Lower limit: $-\frac{\pi}{2} \times \Delta D_o$ (rounded up to the nearest 0,005 mm)

7.3 Obtaining data — Example

Given:

Bush ISO 3547 — 30A 34 × 30 — S3

Outside diameter: $D_o = \left(34 \begin{smallmatrix} +0,085 \\ +0,045 \end{smallmatrix}\right) \text{ mm}$

(in accordance with ISO 3547-1:2006, Table 7)

Nominal wall thickness: $s_2 = 2$

Nominal thickness of the steel backing: $s_1 = 1,55 \text{ mm}$ (see Table 3)

$$s_2 = s_3 - s_1$$

$$= 2 \text{ mm} - 1,55 \text{ mm}$$

$$s_2 = 0,45 \text{ mm}$$

Nominal width: $B = 30 \text{ mm}$

Material: steel/copper alloy S3 (in accordance with ISO 3547-4:2006).

Results:

From 7.2.2:

$$d_{\text{ch},1} = D_{o, \text{max}} - v$$

$$= 34,085 \text{ mm} - 0,013 \text{ mm}$$

$$d_{\text{ch},1} = 34,072 \text{ mm}$$

From 7.2.3:

$$A_{\text{cal}} = B \times \left(s_1 + \frac{s_2}{2} \right)$$

$$= 30 \times \left(1,55 + \frac{0,45}{2} \right) \text{ mm}^2$$

$$A_{\text{cal}} = 53,25 \text{ mm}^2$$

From 7.2.4:

$$F_{ch} = 6\,000 \times \frac{A_{cal}}{d_{ch,1}}$$

$$= 6\,000 \times \frac{53,25}{34,072} = 9\,377 \text{ N}$$

$$F_{ch} = 9\,500 \text{ N (rounded up to the nearest 500 N)}$$

From 7.2.5:

$$\Delta z$$

Upper limit:

$$0$$

Lower Limit:

$$-\frac{\pi}{2} \times \Delta D_o$$

$$-\frac{\pi}{2} \times 0,040 \text{ mm} = -0,0628 \text{ mm} = -0,065 \text{ mm}$$

(rounded up to the nearest 0,005 mm)

7.4 Presentation of data on drawing — Example

See Figure 2 for an example of how the data obtained in 7.3 should be presented on the drawing.

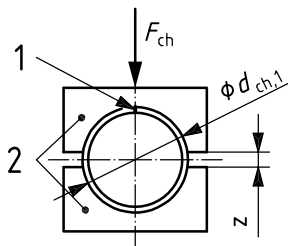

Key

- 1 position of split
- 2 checking block

Test A to ISO 3547-2

Checking block and setting plug

$$d_{ch,1} = d_{ch,2} = 34,072 \text{ mm}$$

Checking load

$$F_{ch} = 9\,500 \text{ N}$$

Limit for

$$\Delta z = 0 \text{ and } -0,065 \text{ mm}$$

Outside diameter

$$D_o = 34,045 \text{ to } 34,085 \text{ mm}$$

Figure 2 — Example of presentation of data on drawing

8 Test B

8.1 Description

The test is applicable to $2D_o$ up to 120 mm.

The test is carried out with two ring gauges, a GO ring gauge and a NO GO ring gauge.

The gauge diameters are determined empirically, based on the maximum and minimum values of the outside diameter (see ISO 3547-1:2006, Table 7) to be checked, and shall be agreed between supplier and user.

It shall be possible to press the bush into the GO ring gauge with hand pressure (maximum force 250 N). However, with the same force it shall not be possible for the bush to enter the NO GO ring gauge (see ISO 3547-5).

NOTE In some cases, the accuracy of the check could be affected, e.g. by the out of roundness of the bush or by butt joints which are not closed. For this reason Test A is preferred.

8.2 Obtaining data — Example

Given:

Bush ISO 3547 — 30A 34 × 30 — S3

Outside diameter: $D_o = \left(34 \begin{array}{l} + 0,085 \\ + 0,045 \end{array} \right) \text{ mm}$

Material: steel/copper alloy S3 (in accordance with ISO 3547-4:2006)

GO gauge diameter = 34,095 mm (found empirically)

NO GO gauge diameter = 34,045 mm (found empirically)

8.3 Presentation of data on drawing — Example

The data obtained should be presented on the drawing as in the following example:

Test B to ISO 3547-2

GO gauge diameter = 34,095 mm

NO GO gauge diameter = 34,045 mm

9 Test C

9.1 Description

In order to check the inside diameter, D_i , the bush is pressed into a ring gauge, whose nominal diameter corresponds to the dimension specified in Table 6. Other details of the ring gauge should be according to ISO 3547-6.

The test is applicable to $2D_i$ up to 120 mm.

Inside diameter $D_{i, \text{ch}}$ shall be measured with a three-point measuring instrument in accordance with ISO 12301, or checked with a GO and NO GO plug gauge.

The plug gauges are calculated from the ring gauge diameter, $d_{\text{ch}, 1}$, as follows.

GO plug: $d_{\text{ch}, 1} - 2 \times s_3, \text{ max.}$

NO GO plug: $d_{\text{ch}, 1} - 2 \times s_3, \text{ min.}$

The GO plug gauge shall enter the bush with minimum effort; the NO GO plug gauge shall not enter the bush manually (maximum force 250 N).

When the bush is pressed into the ring gauge, it is possible that there will be a permanent reduction in the outside diameter.

In order to enable the supplier and user to compare results, the test method should be agreed between them.

Table 6 — Ring gauge inside diameter, $d_{ch,1}$, for checking bush inside diameter, $D_{i,ch}$

Dimensions in millimetres

D_o nominal		$d_{ch,1}^a$
	≤ 10	$D_o + 0,008$
> 10	≤ 18	$D_o + 0,009$
> 18	≤ 30	$D_o + 0,011$
> 30	≤ 50	$D_o + 0,013$
> 50	≤ 80	$D_o + 0,015$
> 80	≤ 120	$D_o + 0,018$
> 120	≤ 175	$D_o + 0,020$

^a The size of $d_{ch,1}$ is made up of D_o and the rounded average value of the tolerance class H7.

9.2 Obtaining data — Example

Given:

Bush ISO 3547 — 30B 34 × 30

Material: multilayer material P1 (in accordance with ISO 3547-4:2006)

Ring gauge inside diameter: $d_{ch,1} = 34,013$ mm (in accordance with Table 6)

Wall thickness: $s_3 = \left(2 \begin{smallmatrix} +0,005 \\ -0,030 \end{smallmatrix} \right)$ mm
(in accordance with ISO 3547-1:2006, Table 5, series B)

GO plug diameter: $d_{ch,2,min} = d_{ch,1} - 2 \times s_{3,max}$
 $= 34,013 \text{ mm} - 2 \times 2,005 \text{ mm}$
 $= 30,003 \text{ mm}$

NO GO plug diameter: $d_{ch,2,max} = d_{ch,1} - 2 \times s_{3,min}$
 $= 34,013 \text{ mm} - 2 \times 1,97 \text{ mm}$
 $= 30,073 \text{ mm}$

9.3 Presentation of data on drawing — Example

See Figure 3 for an example of how the data obtained in 9.2 should be presented on the drawing.

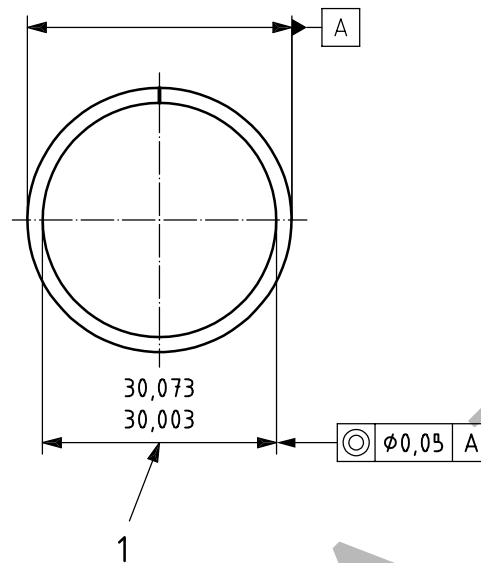

Test C — Gauging — to ISO 3547-2

^a With bush pressed into a ring gauge with $d_{ch,1} = 34,013$ mm.

Figure 3 — Example of presentation of data on drawing

10 Test D

10.1 Description

This method is applicable to bushes above 120 mm in diameter.

A precision measuring tape is used to measure the circumference of the bush.

Details of this text shall be agreed between supplier and user.

10.2 Obtaining data — Example

Given:

Bush ISO 3547 — 200A 205 × 100 — S3

Outside diameter: $D_o = \left(205 \begin{matrix} +0,225 \\ +0,125 \end{matrix} \right)$ mm

Material: steel/copper alloy S3 (in accordance with ISO 3547-4:2006)

10.3 Presentation of data on drawing — Example

See Figure 4 for an example of how the data obtained in 10.2 should be presented on the drawing.

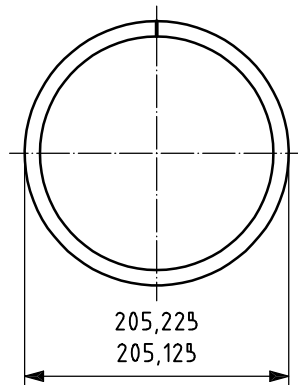

Test D to ISO 3547-2

Figure 4 — Example of presentation of data on drawing

11 Designation of tests according to this part of ISO 3547

Test A is designated by

Test ISO 3547-2 — A

Test B is designated by

Test ISO 3547-2 — B

Test C is designated by

Test ISO 3547-2 — C

Test D is designated by

Test ISO 3547-2 — D