

---

# Plain bearings — Wrapped bushes —

## Part 1: Dimensions

IDEAL

INTERNATIONAL  
STANDARD

ISO  
3547-1

Second edition  
2006-10-15

---

---

**Plain bearings — Wrapped bushes —**  
**Part 1:**  
**Dimensions**

*Paliers lisses — Bagues roulées —*  
*Partie 1: Dimensions*



Reference number  
ISO 3547-1:2006(E)

**Contents**

Page

Foreword..... iv

1 Scope .....1

2 Normative references .....1

3 Terms and definitions .....1

4 Symbols and units .....2

5 Dimensions.....2

6 Design .....10

7 Example for calculation of inside diameter,  $D_i$  .....11

8 Designation .....12

Bibliography .....13

DRAFT

## Foreword

ISO (the International Organization for Standardization) is a worldwide federation of national standards bodies (ISO member bodies). The work of preparing International Standards is normally carried out through ISO technical committees. Each member body interested in a subject for which a technical committee has been established has the right to be represented on that committee. International organizations, governmental and non-governmental, in liaison with ISO, also take part in the work. ISO collaborates closely with the International Electrotechnical Commission (IEC) on all matters of electrotechnical standardization.

International Standards are drafted in accordance with the rules given in the ISO/IEC Directives, Part 2.

The main task of technical committees is to prepare International Standards. Draft International Standards adopted by the technical committees are circulated to the member bodies for voting. Publication as an International Standard requires approval by at least 75 % of the member bodies casting a vote.

Attention is drawn to the possibility that some of the elements of this document may be the subject of patent rights. ISO shall not be held responsible for identifying any or all such patent rights.

ISO 3547-1 was prepared by Technical Committee ISO/TC 123, *Plain bearings*, Subcommittee SC 3, *Dimensions, tolerances and construction details*.

This second edition cancels and replaces the first edition (ISO 3547-1:1999), which has been technically revised.

ISO 3547 consists of the following parts, under the general title *Plain bearings — Wrapped bushes*:

- *Part 1: Dimensions*
- *Part 2: Test data for outside and inside diameters*
- *Part 3: Lubrication holes, grooves and indentations*
- *Part 4: Materials*

The following parts are under preparation:

- *Part 5: Checking the outside diameter*
- *Part 6: Checking the inside diameter*
- *Part 7: Measurement of wall thickness of thin-walled half-bearings and thin-walled bushes*

# Plain bearings — Wrapped bushes —

## Part 1: Dimensions

### 1 Scope

This part of ISO 3547 specifies the dimensions and designations of cylindrical and flanged wrapped bushes made of solid and multi-layer bearing material for plain bearing applications.

### 2 Normative references

The following referenced documents are indispensable for the application of this document. For dated references, only the edition cited applies. For undated references, the latest edition of the referenced document (including any amendments) applies.

ISO 3547-2:2006, *Plain bearings — Wrapped bushes — Part 2: Test data for outside and inside diameters*

ISO 3547-4, *Plain bearings — Wrapped bushes — Part 4: Materials*

ISO 4378-1, *Plain bearings — Terms, definitions and classification — Part 1: Design, bearing materials and their properties*

ISO 12301, *Plain bearings — Quality control techniques and inspection of geometrical and material quality characteristics*

ISO 13715, *Technical drawings — Edges of undefined shape — Vocabulary and indication*

### 3 Terms and definitions

For the purposes of this document, the terms and definitions given in ISO 4378-1 apply.

## 4 Symbols and units

See Table 1.

**Table 1 — Symbols and units**

Symbol	Description	Unit
$B$	Width of the bush	mm
$C_i$	Inside chamfer	mm
$C_o$	Outside chamfer	mm
$D_i$	Inside diameter of the bush	mm
$D_{i, ch}$	Inside diameter of the bush in the ring gauge	mm
$D_{fl}$	Flange diameter	mm
$D_H$	Housing bore diameter	mm
$D_o$	Outside diameter of the bush	mm
$D_S$	Shaft diameter	mm
$d_{ch, 1}$	Diameter of the checking block or ring gauge	mm
$r$	Flange radius	mm
$Ra$	Surface roughness	$\mu\text{m}$
$s_1$	Thickness of the backing layer <sup>a</sup>	mm
$s_2$	Thickness of the bearing material layer <sup>a</sup>	mm
$s_3$	Wall thickness <sup>a</sup>	mm
$s_{fl}$	Flange thickness	mm

<sup>a</sup> For bushes which are made of a single material  $s_1 = s_3$  or  $s_2 = s_3$ .

## 5 Dimensions

See Figure 1 and Tables 2 to 4.

The largest dimension of the inside diameter of the bush in its pressed-in condition is obtained from the largest dimension of the bore in the housing minus twice the smallest dimension of the wall thickness,  $s_3$ . The smallest dimension of the inside diameter of the bush in its pressed-in condition can be obtained from the smallest dimension of the bore in the housing minus twice the greatest dimension of the wall thickness,  $s_3$ . This assumes that there is no expansion of the bore in the housing caused by pressing in the bush. In reality, the expansion depends on several factors, such as the stiffness of the housing and the bush. An example of the calculation is given in Clause 7.

The wall thickness limit deviation depends on whether or not there is a machining allowance in the bush bore and on the material type, as specified in ISO 3547-4. The preferred limit deviation series (A to E) is specified in Table 5.

Instead of the wall thickness, the inside diameter,  $D_{i, ch}$ , of the bush may be specified.  $D_{i, ch}$  is the inside diameter of the bush, when this is pressed into a ring gauge (Test C — gauging — in accordance with ISO 3547-2:2006, see also ISO 3547-6).

For bushes which are supplied with a machined bore (Series W), the limit deviations of the inside diameter of the bush,  $D_{i, ch}$ , checked in a ring gauge, are given in Table 6.

In no case shall wall thickness and inside diameter be given at the same time as the dimensions that are to be checked.

The tolerance for the inside diameter,  $D_{i, ch}$ , of the bush in the ring gauge is given in Table 6. The tolerance of the inside diameter of a bush pressed into a housing is found from the sum of the tolerance for,  $D_{i, ch}$ , and the tolerance of the housing bore. As in the case of the calculation of the inside diameter from the wall thickness, it is assumed that there is no expansion of the housing bore.

Dimensions for the outside diameter,  $D_o$ , of the bush are given in Table 7.

IDEAL

Dimensions in millimetres

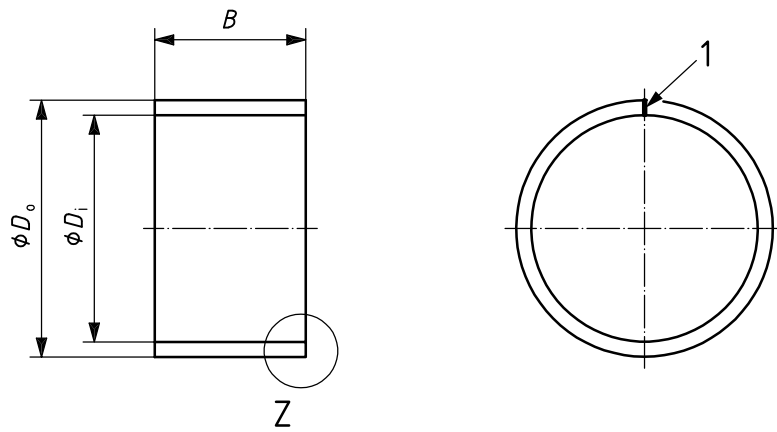

Type C cylindrical bush

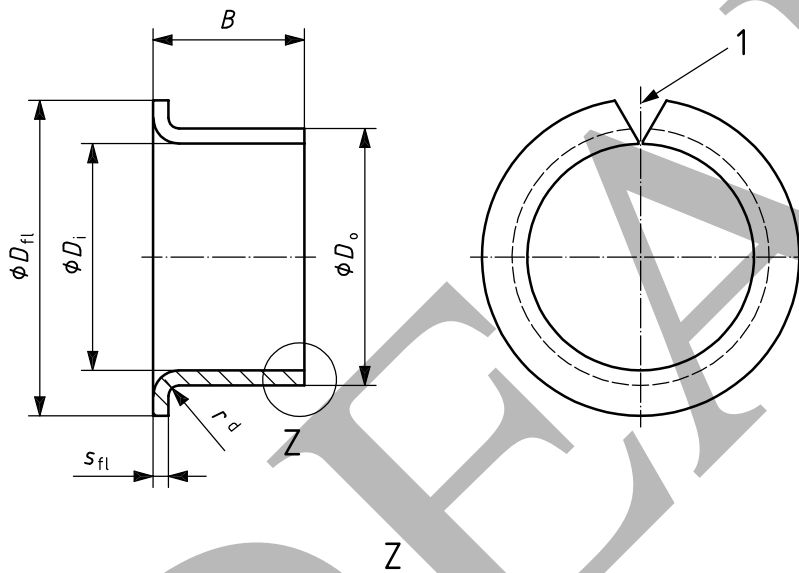

Type F flanged bush

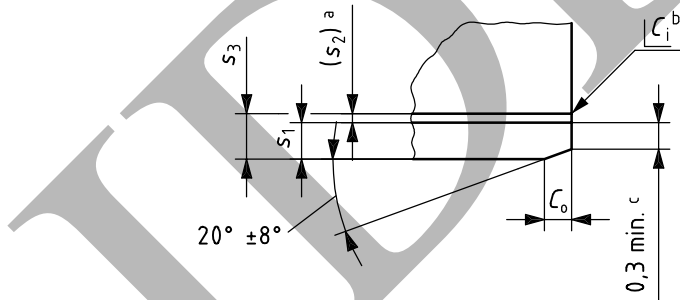

**Key**

1 split

a Thickness of the bearing material layer: only valid as a basis for calculation in accordance with ISO 3547-2.

b  $C_i$  may be a chamfer or break edge, in accordance with ISO 13715.

c 0,2 mm min. for nominal wall thickness 0,5 mm.

d  $r_{\max} = s_3$

**Figure 1 — Cylindrical and flanged bush**

**Table 2 — Preferred nominal dimensions for inside diameter,  $D_i$ , outside diameter,  $D_o$ , wall thickness,  $s_3$ , and bush width,  $B$**

Dimensions in millimetres

$s_3 = 0,5$															
$D_i$	$D_o$	$s_3$	$B$												
			3	4	5	6	8	10	12						
2	3	0,5	a		a										
3	4	0,5	a		a	a									
4	5	0,5	a	a		a									
5	6	0,5			a		a	a							
6	7	0,5		a		a	a	a							
8	9	0,5				a	a	a	a			a			
10	11	0,5						a	a	a		a			
$s_3 = 0,75$															
$D_i$	$D_o$	$s_3$	$B$												
			3	4	5	6	7	8	10						
2	3,5	0,75	a		a										
3	4,5	0,75	a		a	a									
4	5,5	0,75	a	a		a						a			
$s_3 = 1,0$															
$D_i$	$D_o$	$s_3$	$B$												
			3	4	5	6	7	8	10	12	15	20	25		
3	5	1,0	a	a	a	a									
4	6	1,0	a	a		a									
6	8	1,0			a	a	a	a	a						
7	9	1,0			a		a		a	a					
8	10	1,0			a	a	a	a	a	a					
9	11	1,0							a						
10	12	1,0				a	a	a	a	a	b	b			
12	14	1,0				a	a	a	a	a	b	b	b		
13	15	1,0								a		b	b		
14	16	1,0								a	a	b	b	b	
15	17	1,0								a	a	b	b	b	
16	18	1,0								a	a	b	b	b	
17	19	1,0										b	b		
18	20	1,0								a		b	b	b	

Table 2 (continued)

$s_3 = 1,5 \text{ mm}$													
$D_i$	$D_o$	$s_3$	$B$										
			8	10	12	15	20	25	30	40			
8	11	1,5		b	b								
10	13	1,5		a	a	a	a						
12	15	1,5		b	b	b							
13	16	1,5		b	b	b	b						
14	17	1,5		b	b	b	b						
15	18	1,5		a	a	a	a	a					
16	19	1,5		a	a	a	b	a					
18	21	1,5				a	b	b					
20	23	1,5			a	a	b	b	b				
22	25	1,5				a	b	b	b				
24	27	1,5				a	b	b	b				
25	28	1,5				a	b	b	b				
28	31	1,5					b	b	b				
$s_3 = 2 \text{ mm}$													
$D_i$	$D_o$	$s_3$	$B$										
			15	20	25	30	40	50	60	70	80		
28	32	2,0	a	a	a	b		b					
30	34	2,0	a	a	a	b	b						
32	36	2,0		a		b	b						
35	39	2,0		a		b	b	b					
37	40	2,0		a		b	b						
38	42	2,0		a		b	b						
40	44	2,0		a		b	b	b					
$s_3 = 2,5 \text{ mm}$													
$D_i$	$D_o$	$s_3$	$B$										
			20	25	30	40	50	60	70	80	100	115	
45	50	2,5	a		a	b	b						
50	55	2,5	a	a	a	b	b	b					
55	60	2,5	a		a	b		b					
60	65	2,5	a		a	b	b		c				
65	70	2,5			a		b		c				
70	75	2,5			a		b		c				
75	80	2,5				b		b		c			
80	85	2,5				b		b		c	c		
85	90	2,5				b		b		c	c		

**Table 2 (continued)**

$D_i$	$D_o$	$s_3$	$B$									
			20	25	30	40	50	60	70	80	100	115
90	95	2,5				b		b			c	
95	100	2,5						b			c	
100	105	2,5						b	b		c	c
105	110	2,5						b			c	c
110	115	2,5						b			c	c
115	120	2,5						b	b	b	c	
120	125	2,5						b	b		c	
125	130	2,5						b			c	
130	135	2,5						b			c	
135	140	2,5						b		b	c	
140	145	2,5						b			c	
150	155	2,5						b		b	c	
160	165	2,5						b		b	c	
170	175	2,5									c	
180	185	2,5									c	
200	205	2,5									c	
220	225	2,5									c	
250	255	2,5									c	
300	305	2,5									c	

Limit deviations for  $B$ :

a  $\pm 0,25$

b  $\pm 0,5$

c  $\pm 0,75$

Bush widths  $B$  outside the tolerance ranges a, b or c should be agreed between the manufacturer and user and stated after the nominal sizes in the standard designation.

If it is necessary to use non-standard widths  $B$ , then these should be arranged to have an end figure of 2, 5 and 8 up to  $D_i = 50$  mm, and an end figure of 5 over  $D_i = 50$  mm. Check bush width  $B$  in accordance with ISO 12301.

**Table 3 — Preferred nominal dimensions and limit deviations for wrapped flanged bushes**

Dimensions in millimetres

$D_i$	$D_o$	$s_3$	$D_{fl}$		$S_{fl}$	$r_{max}$	$B$																			
			nominal	limit deviation			4	5,5	7	7,5	8	9	9,5	11,5	12	16	16,5	17	21,5	22	26					
6	8	1	12	+0,5 -0,8	1,05 0,80	1	a				a															
8	10	1	15			1		a		a			a													
10	12	1	18			1			a			a			a				b							
12	14	1	20			1			a			a			a				b							
14	16	1	22			1									a				b							
15	17	1	23			1						a			a				b							
16	18	1	24			1									a				b							
18	20	1	26			1									a				b				b			
20	23	1,5	30	+1 -0,8	1,6	1,5							a			a		b								
25	28	1,5	35		1,3	1,5								a			a		b							
30	34	2	42	+2 -0,8	2,1	2								a								b				
35	39	2	47			1,8	2								a								b			
40	44	2	52		2									a								b				
45	50	2,5	58		2,6 2,3	2,5									a								b			

Limit deviations for  $B$ :

a  $\pm 0,25$

b  $\pm 0,5$

**Table 4 — Outside,  $C_o$ , and inside,  $C_i$ , chamfers**

Dimensions in millimetres

Wall thickness $s_3$ Nominal dimension	Chamfer		$C_i$
	$C_o$ machined	rolled	
0,5	0,2 $\pm$ 0,1		-0,05 -0,30
0,75	0,5 $\pm$ 0,3	0,5 $\pm$ 0,3	-0,1 -0,4
1	0,6 $\pm$ 0,4	0,6 $\pm$ 0,4	-0,1 -0,6
1,5	0,6 $\pm$ 0,4	0,6 $\pm$ 0,4	-0,1 -0,7
2	1,2 $\pm$ 0,4	1,0 $\pm$ 0,4	-0,1 -0,7
2,5	1,8 $\pm$ 0,6	1,2 $\pm$ 0,4	-0,2 -1,0

For bushes which have to be machined to size in the bush bore,  $C_i$  should be made correspondingly bigger.

$C_o$  may be machined or rolled at the option of the manufacturer.

$C_i$  may be a chamfer or break edge in accordance with ISO 13715.

**Table 5 — Nominal dimensions and limit deviations for wall thickness,  $s_3$**

Dimensions in millimetres

Nominal dimension	Limit deviations for $s_3$				
	No machining allowance in bush bore			Machining allowance in bush bore	
	Series A	Series B	Series D	Series C	Series E
0,5	0 -0,015	0 -0,030	—	—	—
0,75	0 -0,015	0 -0,020	—	+ 0,25 + 0,15	—
1	0 -0,015	+ 0,005 -0,020	- 0,020 -0,045	+ 0,25 + 0,15	+ 0,11 + 0,07
1,5	0 -0,015	+ 0,005 -0,025	- 0,025 -0,055	+ 0,25 + 0,15	+ 0,11 + 0,07
2	0 -0,015	+ 0,005 -0,030	- 0,030 -0,065	+ 0,25 + 0,15	+ 0,11 + 0,07
2,5	$D_o \leq 80$	0 -0,020	+ 0,005 -0,040	+ 0,30 + 0,15	+ 0,14 + 0,07
	$80 < D_o \leq 120$	0 -0,025	- 0,010 -0,060		
	$D_o > 120$	0 -0,030	- 0,035 -0,085		

Depending on the manufacturing process used, the back of bushes can show isolated slight depressions. The thickness of the walls shall, therefore, be measured at places away from these depressions.

**Table 6 — Series W — Limit deviations for inside diameter,  $D_{i, ch}$ , of bush in ring gauge in accordance with ISO 3547-2**

Dimensions in millimetres

$D_i$ nominal		Limit deviations for $D_{i, ch}$
	$\leq 10$	+ 0,036 0
> 10	$\leq 18$	+ 0,043 0
> 18	$\leq 30$	+ 0,052 0
> 30	$\leq 50$	+ 0,062 0
> 50	$\leq 80$	+ 0,074 0
> 80	$\leq 120$	+ 0,087 0
> 120	$\leq 175$	+ 0,100 0

The concentricity of the inside and outside diameters of the bush should be 0,05 mm, unless otherwise agreed.

**Table 7 — Dimensions and limit deviations for outside diameter,  $D_o$**

Dimensions in millimetres

$D_o$ nominal		Limit deviations for bushes made of	
		steel, steel/backed material	aluminium alloys, copper alloys, aluminium alloy backed material, copper alloy backed material
	$\leq 10$	+ 0,055 + 0,025	+ 0,075 + 0,045
> 10	$\leq 18$	+ 0,065 + 0,030	+ 0,080 + 0,050
> 18	$\leq 30$	+ 0,075 + 0,035	+ 0,095 + 0,055
> 30	$\leq 50$	+ 0,085 + 0,045	+ 0,110 + 0,065
> 50	$\leq 80$	+ 0,100 + 0,055	+ 0,125 + 0,075
> 80	$\leq 120$	+ 0,120 + 0,070	+ 0,140 + 0,090
> 120	$\leq 180$	+ 0,170 + 0,100	+ 0,190 + 0,120
> 180	$\leq 305$	+ 0,255 + 0,125	+ 0,245 + 0,145

## 6 Design

In its free state, a wrapped bush might not be perfectly cylindrical and its split can be open. After it has been pressed into its housing, in general, a wrapped bush is round and its split is closed. Wrapped bushes can be closed by an interlocked split. The design of the split is left at the discretion of the manufacturer.

Wrapped bushes are supplied with or without a machining allowance in the bore. Bushes supplied with a machining allowance are finish-machined to the desired dimensions by the customer after they have been pressed into their housings. Such bushes cannot be supplied in all materials.

Wrapped bushes which comply with this part of ISO 3547 are supplied in the limit deviations series A to E, as specified in Table 5, and Series W, as specified in Table 6.

Lubrication holes, lubrication grooves or lubrication indents should preferably be designed such that they can be stamped or punched. Distortion caused by the wrapping operation is permissible. All edges and corners shall be free from loose burrs. Burrs which do not affect installation or function are permissible.

ISO 3547-2:2006, Test B, does not stipulate any figure for outside diameter,  $D_o$ . In order to obtain a sufficiently tight fit of the bush in the housing bore when using test B, experimentally determined gauge inside diameters are used. These depend on the method of manufacture and cannot therefore apply in every single case. Specification of a maximum and minimum pressing in force increases the safety of this test method. The details of test should be agreed for each individual case.

The tolerance class of the housing bore diameter is given in Table 8.

**Table 8 — Tolerance class of the housing bore diameter,  $D_H$**

Dimensions in millimetres

$D_i$ Nominal		Tolerance class of housing bore $D_H$
	$\leq 4$	H 6
$> 4$	$\leq 75$	H 7
$> 75$		H 7

Selection of the tolerance class of the shaft will depend on the material type and application

The recommended surface roughness of the housing bore is  $Ra$  1,6 to 3,2  $\mu\text{m}$  and of the shaft  $Ra$  0,2 to 0,4  $\mu\text{m}$ .

Surface roughness values are given in accordance with Table 9.

**Table 9 — Surface roughness,  $Ra$ , for bushes (in accordance with ISO 4288)**

Surface	$Ra$ $\mu\text{m}$				
	A	B	Series C/E	D	W
Bearing bore, $D_i$	0,8	1,6 <sup>a</sup>	6,3	1,6	1,6
Back of bearing, $D_o$	1,6	1,6	1,6	1,6	1,6
Other surfaces	25	25	25	25	25

<sup>a</sup> For bushes made of B1 and P1 material according to ISO 3547-4,  $Ra \leq 6,3 \mu\text{m}$ .

## 7 Example for calculation of inside diameter, $D_i$

Calculation of the size limits of inside diameter,  $D_i$ , in the pressed in condition of a bush of nominal outside diameter of 34 mm and nominal wall thickness of 2 mm:

bore diameter of housing  $D_H = \left( 34 \begin{smallmatrix} +0,025 \\ 0 \end{smallmatrix} \right) \text{ mm}$

outside diameter of bush  $D_o = \left( 34 \begin{smallmatrix} +0,085 \\ +0,045 \end{smallmatrix} \right) \text{ mm}$

wall thickness of bush  $s_3 = \left( 2 \begin{smallmatrix} 0 \\ -0,015 \end{smallmatrix} \right) \text{ mm}$

$$D_{i,\max} = 34,025 - (2 \times 1,985) = 30,055 \text{ mm}$$

$$D_{i,\min} = 34,000 - (2 \times 2,000) = 30,000 \text{ mm}$$

As a result of interference fit there will be a small expansion of the housing bore diameter,  $D_H$ , after assembly of the bush. This will depend on the rigidity of the housing.

For rigid housing bores (steel), a figure of approximately one sixth of the difference between the mid-limit of the bush outside diameter,  $D_o$ , and the mid-limit of the diameter of the housing bore may be taken for the expansion of the housing bore due to the pressing in of the bush.

## 8 Designation

The following are examples of the designation of bushes conforming to ISO 3547.

EXAMPLE 1 A wrapped cylindrical bush (Type C) of inside diameter  $D_i = 30$  mm, wall thickness deviation limit Series A, having an outside diameter  $D_o = 34$  mm and width  $B = 20$  mm, made of a multi-layer material, code S5, in accordance with ISO 3547-4, with a lubrication hole and a circumferential groove of design M1A, and with lubrication indentations of design N1B, in accordance with ISO 3547-3, and where ISO 3547-2:2006, test A, and wall thickness measurements are specified, is designated as follows:

**Bush ISO 3547 — C30 A 34 × 20 — S5 — M1A N1B — AS**

NOTE "S" signifies the required wall thickness measurement in accordance with ISO 3547-7.

EXAMPLE 2 A wrapped flanged bush (Type F) of inside diameter  $D_i = 30$  mm, wall thickness deviation limit Series B, having an outside diameter  $D_o = 34$  mm and width  $B = 16$  mm, made of a multi-layer material, code P1, in accordance with ISO 3547-4, and where ISO 3547-2:2006, Tests A and C, are specified, is designated as follows:

**Bush ISO 3547 — F30 B 34 × 16 — P1 — AC**

EXAMPLE 3 A wrapped cylindrical bush (Type C) of inside diameter  $D_i = 30$  mm, wall thickness deviation limit Series W, having an outside diameter  $D_o = 34$  mm and width  $B = 20$  mm, made in a single material, code Y1, in accordance with ISO 3547-4, and where ISO 3547-2:2006, Tests A and C, are specified, is designated as follows:

**Bush ISO 3547 — C30 W 34 × 20 — Y1 — AC**

## Bibliography

- [1] ISO 4288, *Geometrical Product Specifications (GPS) — Surface texture: Profile method — Rules and procedures for the assessment of surface texture*

IDEAL